

G100 Series Hose Reel

The G100 hose reels are robustly designed for all your general purpose reeling, from a simple air reel to a high pressure grease reel. With a superior power spring to recall all hose. The spring is greased, sealed and housed within the drum.

Applications:

- Air
- Water
- Oils and Lubricants
- Grease
- Other Fluids

Suitable Hose Sizes:

- 20m x 1/4" Oil, Grease Hose
- 20m x 3/8" Air, Oil, Grease Hose
- 18m x 1/2" Air Oil Grease Hose

Swivels Options:

- 3/4" 200 Bar Steel for General Purpose Lubricant
- 1/2" 120 Bar Brass Swivel for Waters and Gas
- 1/2" 600 Bar Steel for High Pressure Grease

Manufactured Materials:

- Drum, Hose Guide & Bosses
 - UV stable High Strength Polymers
- Base and Side Arms
 - Powder-coated mild Steel
- Power Spring
 - Extra Heavy Duty
 - Blue Tempered Spring Steel
- Shaft
 - Heavy duty 40mm OD Mild Steel
 - Zinc Plated
- Nuts and Bolts
 - High Tensile Zinc Plated
- No Aluminum Parts
 - Safe underground

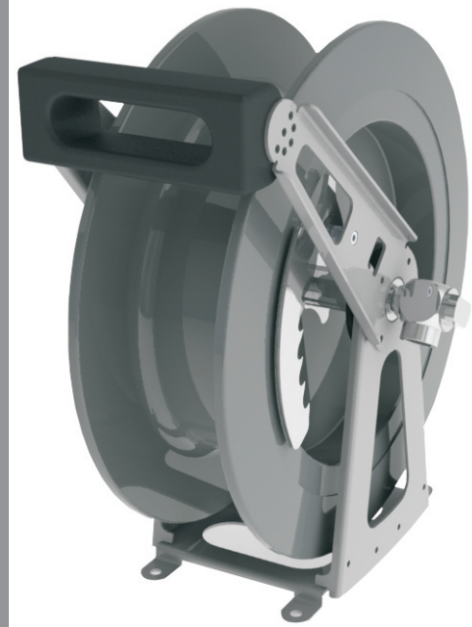

Other Similar Reels:

G120TW
For Oxy & Acetylene
Cutting

G150HW
For long length hand-wind
applications

Custom Reels:

Electric Drives
Hydraulic Drives
Cable Reels & More

Custom designed trailers
and vehicular requirements
with full dispensing to reduce
down time.

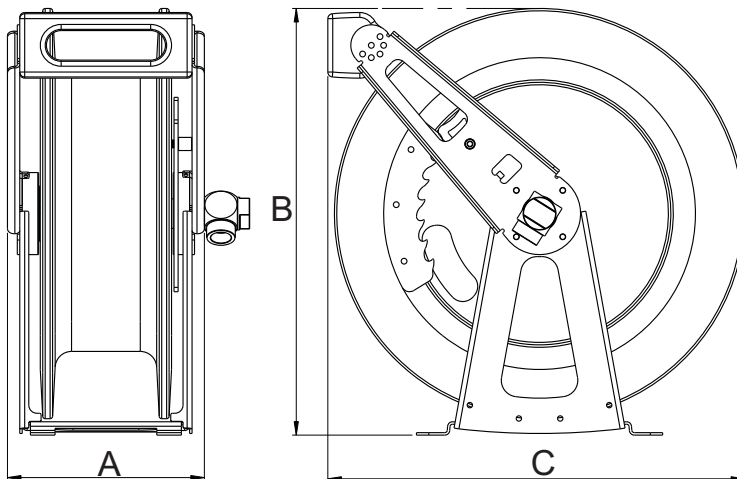

A = 240 mm
B = 520mm
C = 510 mm

Weight = 19kg